

Revision	Rev. Date	Changes Made
Rev. 1 (SB)	09-06-08	20mm min. distance added from top of post
Rev. 2 (SB)	26-08-10	Alternate posts now facing other way
Rev. 3 (MY)	17-01-18	Top of post height reduced from 812mm to 780mm

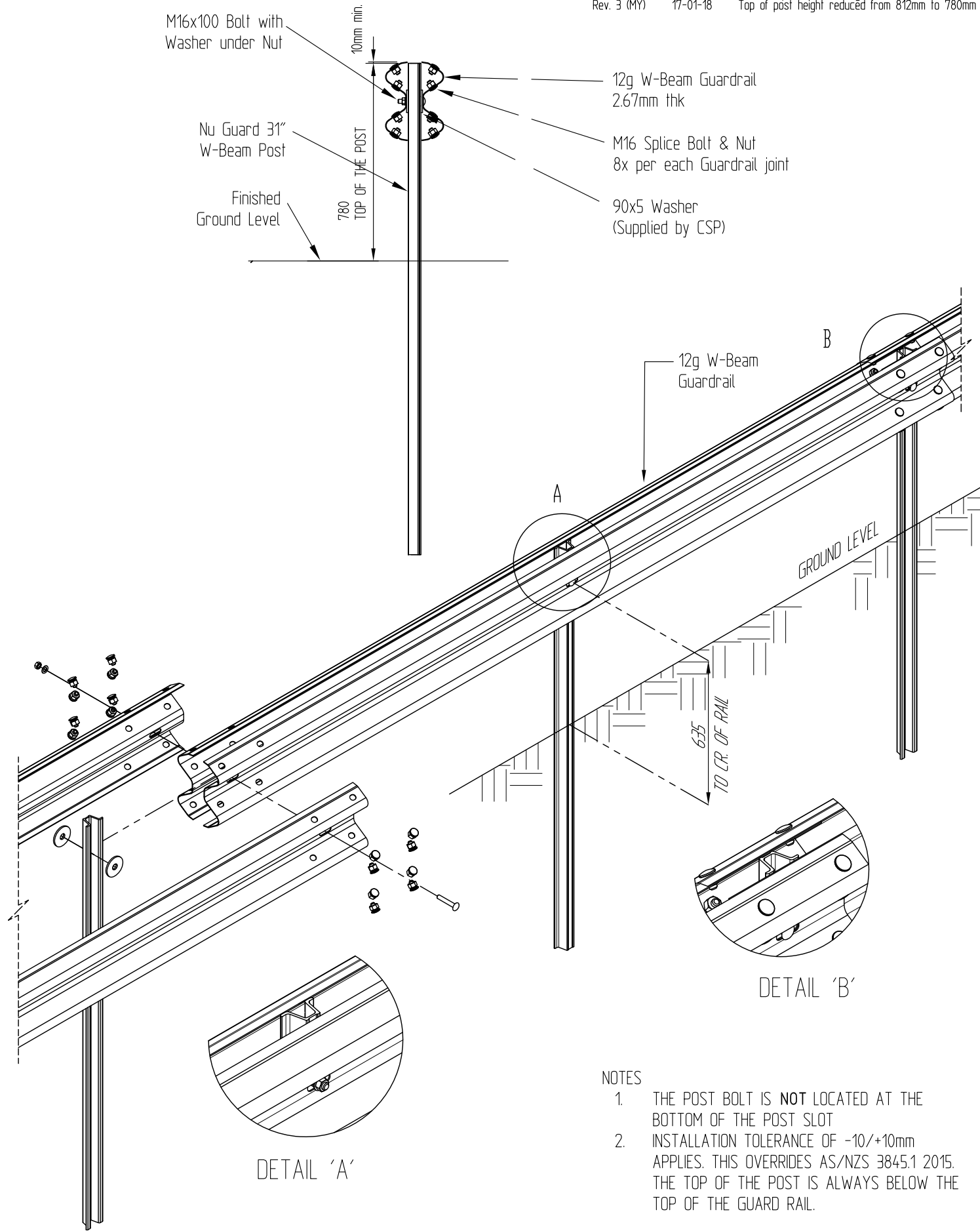

- NOTES
1. THE POST BOLT IS **NOT** LOCATED AT THE BOTTOM OF THE POST SLOT
 2. INSTALLATION TOLERANCE OF $-10/+10$ mm APPLIES. THIS OVERRIDES AS/NZS 3845.1 2015. THE TOP OF THE POST IS ALWAYS BELOW THE TOP OF THE GUARD RAIL.



306 Neilson Street,
 Onehunga, Auckland
 PO Box 12 949, Penrose
 Auckland, New Zealand
 Telephone 09-634 1239
 Facsimile 09-634 4525
 www.csppacific.co.nz

NU-GUARD 31"
 MEDIAN SYSTEM ASSEMBLY DRAWING

Drawn by	MY	Date	30 OCT 17
Checked		Scale A4	1:20
Reference No.			
Drawing no.	FX525	Rev. No.	3

Copyright: This design, information and drawing remain the property of CSP Pacific and may not be used or copied without approval in writing from CSP Pacific.