

Revision	Rev. Date	Changes Made
Rev.1	15/03/99	Tims part no.'s to BPCS part no.'s
Rev.2	08/07/99	Section #2 part no. adjusted
Rev.3	10/07/00	Assembly part no. & weight added
Rev.4	08/03/01	General Drawing Update
Rev.5	09/03/01	Gear Opening Changed to Flush Fit Type
Rev.6	08/05/01	Gear Opening Changed back to Formed Door Type
Rev.7	03/04/04	Added Specifications and notes.
Rev.8	22/01/07	PCD of HDA corrected
Rev.9	19/06/12	General notes and part number updated

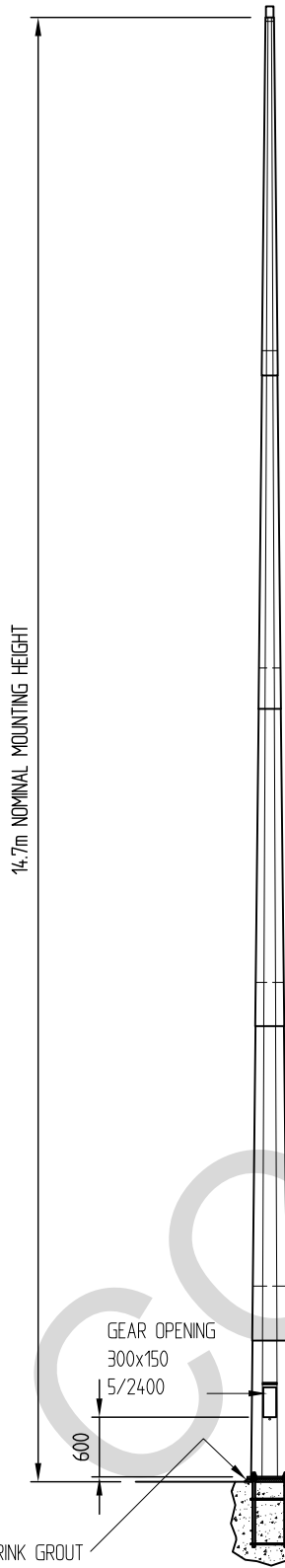

①
 LENGTH 3.6m
 GAUGE 2mm
 PART No. 2110522

②
 LENGTH 3.6m
 GAUGE 2mm
 PART No. 2110524

③
 LENGTH 3.6m
 GAUGE 2mm
 PART No. 2110536

④
 LENGTH 3.6m
 GAUGE 3mm
 PART No. 2110549

⑤
 LENGTH 1.8m
 GAUGE 3mm
 450 x 450 x 20mm MS FLANGE
 PART No. 2110988

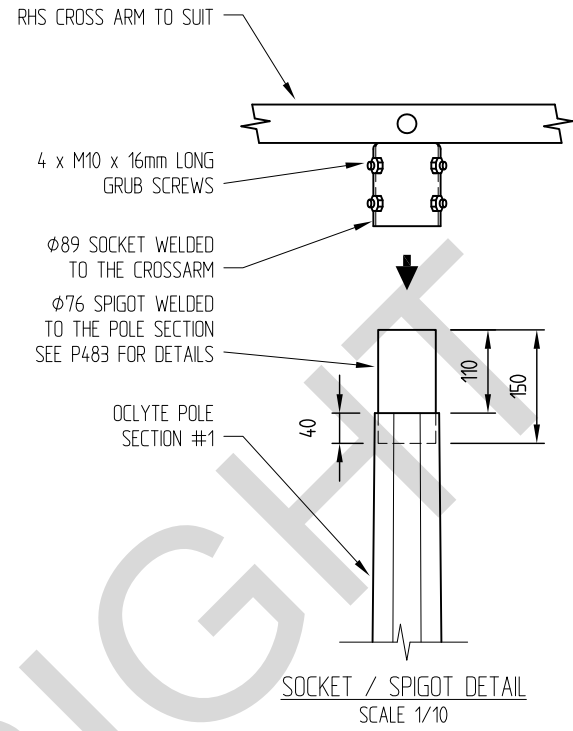

- NOTES**
1. See Installation Instructions for Oclyte™ Columns for assembly and installation - see our web site www.cspacific.co.nz or phone 0800 655 200
 2. Foundation design by others
 3. Column seam welds to be partial penetration butt welds, Category SP to AS/NZS 1554.1. Use CSP Pacific Welding Procedure #8 for 2mm and #8 or #7 for 3mm sections
 4. Steel material - Grade 250 to AS/NZS 3678
 5. All other welds to be fillet welds with a min 5mm leg length, Category SP to AS/NZS 1554.1, unless noted otherwise
 6. Column design to AS/NZS 1170, AS/NZS 4676 and AS/NZS 3404.1
 7. For site specific sail area and base reactions please contact CSP Pacific.
 8. Assembly galvanized weight = 2810 Kg not including crossarm and H.D.A.



306 Neilson Street,
 Onehunga, Auckland
 PO Box 12 949, Penrose
 Auckland, New Zealand
 Telephone 09-634 1239
 Facsimile 09-634 4525
 www.cspacific.co.nz

Copyright. This design, information and drawing remain the property of CSP Pacific and may not be used or copied without approval. In writing from CSP Pacific.

OCLYTE 14.7m NOMINAL MOUNTING HEIGHT
 FLANGE BASE FLOODLIGHT COLUMN
 2 & 3mm GAUGE SECTIONS
 ASSEMBLY PART No. 211092
 (CROSS ARM / HDA NOT INCLUDED)

Drawn by	MJH	Date	02/07/98
Checked		Scale A4	1/75
Reference No.			
Drawing no.	P1331	Rev. No.	9