

Revision	Rev. Date	Changes Made
Rev. 1 (SB)	22-07-11	Title Updated
Rev. 2 (SB)	22-07-11	Notes updated
Rev. 3 (SB)	30-07-11	NZTA approval added
Rev. 4 (SB)	06-07-12	Drawing title description updated
Rev. 5 (LA)	07-08-12	Drawing title description approval notice updated

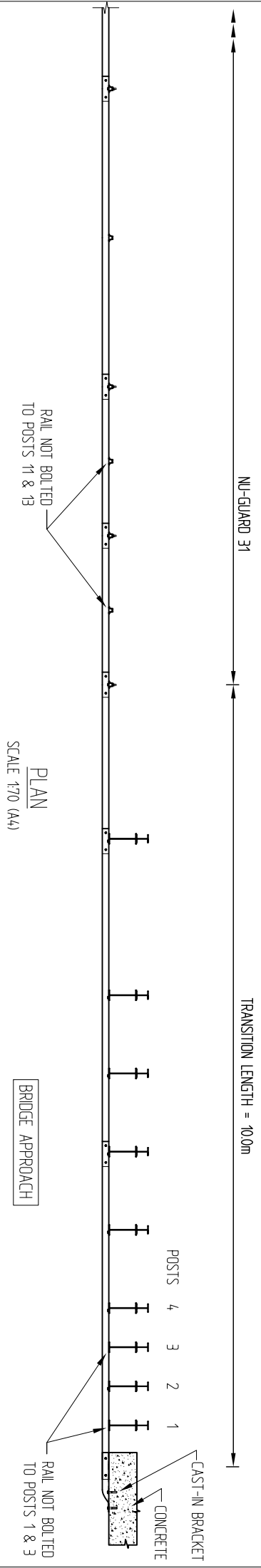

PLAN
SCALE 1:70 (A4)

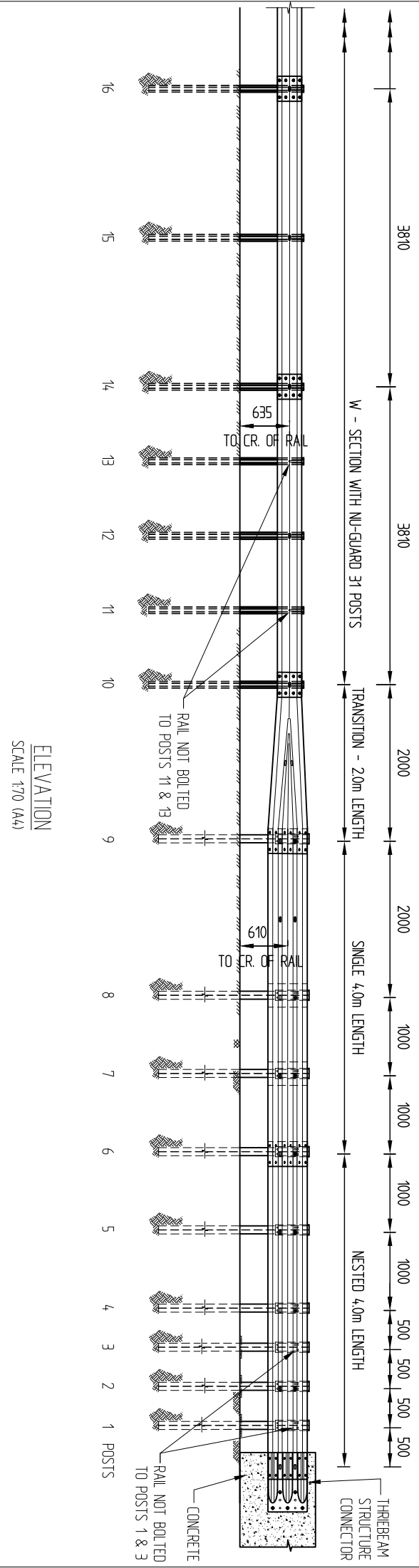

ELEVATION
SCALE 1:70 (A4)

ACCEPTED BY NZ TRANSPORT AGENCY

- NOTES:**
1. THE MINIMUM TRANSITION LENGTH FOR W-SECTION TO CONCRETE IS 10.0m
 2. ALL TRANSITION POSTS TO BE STEEL WITH MODIFIED BLOCKOUTS AS PER AS/NZS 3845:1999
 3. WHERE PROPER POST EMBEDMENT CANNOT BE ACHIEVED, STANDARD 'I' BEAM BRIDGE STEEL POSTS ON STEEL BASE PLATES (AS PER APPENDIX 'B' TRANSIT NZ BRIDGE MANUAL) CAN BE BOLTED TO A CONCRETE BEAM
 4. CENTRE OF RAIL HEIGHT IS 635mm FOR NU-GUARD, 610mm FOR THREEBEAM
 5. THREEBEAM RAIL & POST BOLT HOLES ARE TO BE AT 1000mm CENTRES
 6. POSTS 7 & 8 NEED TO HAVE BACKING PIECES



**306 Neilson Street,
Onehunga, Auckland
PO Box 12 949, Penrose
Auckland, New Zealand
Telephone 09-634 1239
Facsimile 09-634 4525
www.cspacific.co.nz**

TO RIGID BARRIER TRANSITION DETAIL

NU-GUARD 31

Drawn by	SB	Date	08/07/11
Checked		Scale A4	AS SHOWN
Reference No.			
Drawing no.	FX527-3		
Rev. No.	5		