



June 27, 2008

In Reply Refer To: HSSD/B-162B

Mr. Rick Mauer  
Nucor Steel Marion Inc  
912 Cheney Ave  
Marion, Ohio 43302

Dear Mr. Mauer:

This letter is in response to your request for Federal Highway Administration (FHWA) acceptance of a roadside safety system for use on the National Highway System (NHS).

Name of device/system: Nu-Guard 31 inch U-post guardrail  
Type of device/system: Strong post W-beam barrier  
Test Level: NCHRP Report 350 Test Level 4 (TL-4)  
Testing conducted by: Holmes Solutions  
Date of request: February 15, 2008  
Date of final package: April 23, 2008

You requested that we find this system acceptable for use on the NHS under the provisions of National Cooperative Highway Research Program (NCHRP) Report 350 "Recommended Procedures for the Safety Performance Evaluation of Highway Features."

### Requirements

Roadside safety systems should meet the guidelines contained in the NCHRP Report 350, "Recommended Procedures for the Safety Performance Evaluation of Highway Features". FHWA Memorandum "ACTION: Identifying Acceptable Highway Safety Features" of July 25, 1997 provides further guidance on crash testing requirements of longitudinal barriers.

### Description

The Nucor Steel Marion Nu-Guard 31 inch high strong post W-beam guardrail system consists of standard 12 gauge W-beam attached directly to a 5 pound Nucor modified U post section. The steel line posts are hot rolled steel that is rolled into a U cross section approximately 2 inches deep and 3-1/2 inches wide. The total weight of the posts is 5 pounds per foot. Each post is punched with a 3/4 inch wide slot located 1 inch down from the top of the posts in the middle of the cross section. The slot has a total length of 6-1/2 inches. All posts were 78 inches long and hot dip galvanized.

Washers manufactured from 1/4 inch mild steel plate with an outside diameter of 3-1/2 inches and a 1-inch diameter hole were installed between the guard rail and the legs of the U posts to provide a backing plate to the bolt. The washers have a hot dip galvanized finish. The rail

elements are standard 12 gauge BMT (base metal thickness), 350 grade galvanized W-beam, conforming to AASHTO M180 Class A rail. The guardrail system uses standard FBB01 5/8 x 1-1/2 inch galvanized splice bolt and nuts. The W-beams are held to the posts using galvanized 5/8 x 3-1/2 inch bolts with standard FBB01 splice nuts.

### **Crash Testing**

Testing for TL-3 had previously been carried out on the Nu-Guard 31 inch W-beam guardrail system to the requirements of Test 3-10 and Test 3-11 from NCHRP 350, these tests being identical to the requirements of Tests 4-10 and 4-11. The results of these tests were documented in Report 5707-07-b and included in FHWA Acceptance Letter B-162 dated September 11, 2007.

Your current request is for TL-4 acceptance and was accompanied by a report documenting testing in standard soil completed in accordance with Test 4-12 from NCHRP 350; using an 8000S (8000 kg) truck traveling at a nominal 80 km/hr and impacting the barrier at the critical impact point at an angle of 15 degrees. The test data summary sheet of this impact is enclosed for reference.

The roadside barrier configuration of the guardrail system contained and redirected the 8000S upright while sustaining moderate damage. The vehicle began to exit before the captured rail caused the vehicle to continue down the length of the barrier, during which time majority of the posts split open at the post bolt slot and separated from the W-beam. No significant debris was expelled from the barrier during the impact, with only plastic components being released from the front of the vehicle. A localized puncture in the face of the guardrail was observed at the point of impact, caused by contact with the truck foot plate. A maximum dynamic deflection of 4 feet was recorded in the barrier. The total length of damage to the barrier caused by the contact of the vehicle was 79 feet, with 5 feet of the damage occurring upstream from the point of impact.

### **Findings**

The results of the crash test met the evaluation criteria in the NCHRP Report 350. Therefore, the system described above and detailed in the enclosed drawings is acceptable for use as a TL-3 or 4 system on the NHS under the range of conditions tested, when acceptable to a transportation authority.

Please note the following standard provisions that apply to the FHWA letters of acceptance:

- This acceptance is limited to the crashworthiness characteristics of the devices/systems and does not cover their structural features, nor conformity with the Manual on Uniform Traffic Control Devices.
- Any changes that may adversely influence the crashworthiness of the device/system will require a new acceptance letter.
- Should the FHWA discover that the qualification testing was flawed, that in-service performance reveals unacceptable safety problems, or that the device/system being marketed is significantly different from the version that was crash tested, we reserve the right to modify or revoke our acceptance.

- You will be expected to supply potential users with sufficient information on design and installation requirements to ensure proper performance.
- You will be expected to certify to potential users that the hardware furnished has essentially the same chemistry, mechanical properties, and geometry as that submitted for acceptance, and that it will meet the crashworthiness requirements of the FHWA and the NCHRP Report 350.
- To prevent misunderstanding by others, this letter of acceptance is designated as number B-162B and shall not be reproduced except in full. This letter and the test documentation upon which it is based are public information. All such letters and documentation may be reviewed at our office upon request.
- The Nu-Guard barriers are patented products and considered proprietary. If proprietary devices/systems are specified by a highway agency for use on Federal-aid projects, except exempt, non-NHS projects, they: (a) must be supplied through competitive bidding with equally suitable unpatented items; (b) the highway agency must certify that they are essential for synchronization with the existing highway facilities or that no equally suitable alternative exists; or (c) they must be used for research or for a distinctive type of construction on relatively short sections of road for experimental purposes. Our regulations concerning proprietary products are contained in Title 23, Code of Federal Regulations, Section 635.411.
- This acceptance letter shall not be construed as authorization or consent by the FHWA to use, manufacture, or sell any patented device/system for which the applicant is not the patent holder. The acceptance letter is limited to the crashworthiness characteristics of the candidate device/system, and the FHWA is neither prepared nor required to become involved in issues concerning patent law. Patent issues, if any, are to be resolved by the applicant.

Sincerely yours,

David A. Nicol, P.E.  
Director, Office of Safety Design  
Office of Safety

Enclosures

FHWA:HSSD:NArtimovich:tb:x61331:6/12/08

File: s://directory folder/nartimovich/B162B-nucor31inchTL4FIN.doc

cc: HSSD (Reader, HSA; Chron File, HSSD; N.Artimovich, HSSD;  
M.McDonough, HSSD)



June 27, 2008

In Reply Refer To: HSSD/B-162B

Mr. Rick Mauer  
Nucor Steel Marion Inc  
912 Cheney Ave  
Marion, Ohio 43302

Dear Mr. Mauer:

This letter is in response to your request for Federal Highway Administration (FHWA) acceptance of a roadside safety system for use on the National Highway System (NHS).

Name of device/system: Nu-Guard 31 inch U-post guardrail  
Type of device/system: Strong post W-beam barrier  
Test Level: NCHRP Report 350 Test Level 4 (TL-4)  
Testing conducted by: Holmes Solutions  
Date of request: February 15, 2008  
Date of final package: April 23, 2008

You requested that we find this system acceptable for use on the NHS under the provisions of National Cooperative Highway Research Program (NCHRP) Report 350 "Recommended Procedures for the Safety Performance Evaluation of Highway Features."

### Requirements

Roadside safety systems should meet the guidelines contained in the NCHRP Report 350, "Recommended Procedures for the Safety Performance Evaluation of Highway Features". FHWA Memorandum "ACTION: Identifying Acceptable Highway Safety Features" of July 25, 1997 provides further guidance on crash testing requirements of longitudinal barriers.

### Description

The Nucor Steel Marion Nu-Guard 31 inch high strong post W-beam guardrail system consists of standard 12 gauge W-beam attached directly to a 5 pound Nucor modified U post section. The steel line posts are hot rolled steel that is rolled into a U cross section approximately 2 inches deep and 3-1/2 inches wide. The total weight of the posts is 5 pounds per foot. Each post is punched with a 3/4 inch wide slot located 1 inch down from the top of the posts in the middle of the cross section. The slot has a total length of 6-1/2 inches. All posts were 78 inches long and hot dip galvanized.

Washers manufactured from 1/4 inch mild steel plate with an outside diameter of 3-1/2 inches and a 1-inch diameter hole were installed between the guard rail and the legs of the U posts to provide a backing plate to the bolt. The washers have a hot dip galvanized finish. The rail

elements are standard 12 gauge BMT (base metal thickness), 350 grade galvanized W-beam, conforming to AASHTO M180 Class A rail. The guardrail system uses standard FBB01 5/8 x 1-1/2 inch galvanized splice bolt and nuts. The W-beams are held to the posts using galvanized 5/8 x 3-1/2 inch bolts with standard FBB01 splice nuts.

### **Crash Testing**

Testing for TL-3 had previously been carried out on the Nu-Guard 31 inch W-beam guardrail system to the requirements of Test 3-10 and Test 3-11 from NCHRP 350, these tests being identical to the requirements of Tests 4-10 and 4-11. The results of these tests were documented in Report 5707-07-b and included in FHWA Acceptance Letter B-162 dated September 11, 2007.

Your current request is for TL-4 acceptance and was accompanied by a report documenting testing in standard soil completed in accordance with Test 4-12 from NCHRP 350; using an 8000S (8000 kg) truck traveling at a nominal 80 km/hr and impacting the barrier at the critical impact point at an angle of 15 degrees. The test data summary sheet of this impact is enclosed for reference.

The roadside barrier configuration of the guardrail system contained and redirected the 8000S upright while sustaining moderate damage. The vehicle began to exit before the captured rail caused the vehicle to continue down the length of the barrier, during which time majority of the posts split open at the post bolt slot and separated from the W-beam. No significant debris was expelled from the barrier during the impact, with only plastic components being released from the front of the vehicle. A localized puncture in the face of the guardrail was observed at the point of impact, caused by contact with the truck foot plate. A maximum dynamic deflection of 4 feet was recorded in the barrier. The total length of damage to the barrier caused by the contact of the vehicle was 79 feet, with 5 feet of the damage occurring upstream from the point of impact.

### **Findings**

The results of the crash test met the evaluation criteria in the NCHRP Report 350. Therefore, the system described above and detailed in the enclosed drawings is acceptable for use as a TL-3 or 4 system on the NHS under the range of conditions tested, when acceptable to a transportation authority.

Please note the following standard provisions that apply to the FHWA letters of acceptance:

- This acceptance is limited to the crashworthiness characteristics of the devices/systems and does not cover their structural features, nor conformity with the Manual on Uniform Traffic Control Devices.
- Any changes that may adversely influence the crashworthiness of the device/system will require a new acceptance letter.
- Should the FHWA discover that the qualification testing was flawed, that in-service performance reveals unacceptable safety problems, or that the device/system being marketed is significantly different from the version that was crash tested, we reserve the right to modify or revoke our acceptance.

- You will be expected to supply potential users with sufficient information on design and installation requirements to ensure proper performance.
- You will be expected to certify to potential users that the hardware furnished has essentially the same chemistry, mechanical properties, and geometry as that submitted for acceptance, and that it will meet the crashworthiness requirements of the FHWA and the NCHRP Report 350.
- To prevent misunderstanding by others, this letter of acceptance is designated as number B-162B and shall not be reproduced except in full. This letter and the test documentation upon which it is based are public information. All such letters and documentation may be reviewed at our office upon request.
- The Nu-Guard barriers are patented products and considered proprietary. If proprietary devices/systems are specified by a highway agency for use on Federal-aid projects, except exempt, non-NHS projects, they: (a) must be supplied through competitive bidding with equally suitable unpatented items; (b) the highway agency must certify that they are essential for synchronization with the existing highway facilities or that no equally suitable alternative exists; or (c) they must be used for research or for a distinctive type of construction on relatively short sections of road for experimental purposes. Our regulations concerning proprietary products are contained in Title 23, Code of Federal Regulations, Section 635.411.
- This acceptance letter shall not be construed as authorization or consent by the FHWA to use, manufacture, or sell any patented device/system for which the applicant is not the patent holder. The acceptance letter is limited to the crashworthiness characteristics of the candidate device/system, and the FHWA is neither prepared nor required to become involved in issues concerning patent law. Patent issues, if any, are to be resolved by the applicant.

Sincerely yours,

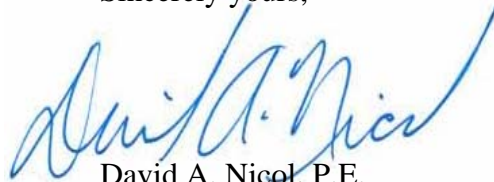
A handwritten signature in blue ink, appearing to read "David A. Nicol".

David A. Nicol, P.E.  
Director, Office of Safety Design  
Office of Safety

Enclosures

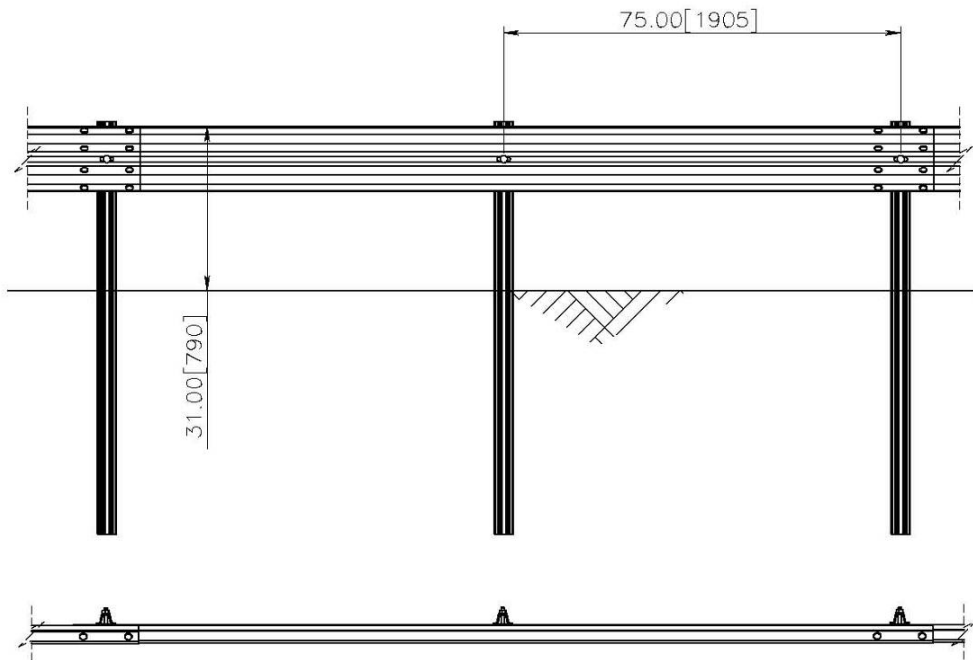
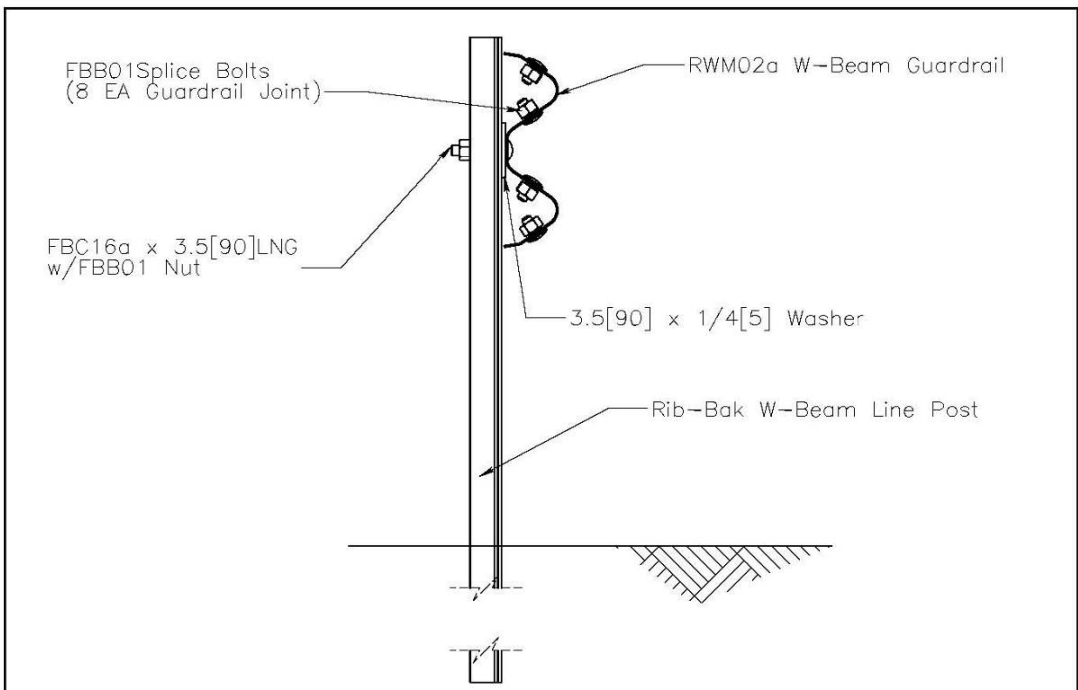

2007

STRONG POST 31" HIGH W-BEAM ROADSIDE BARRIER,  
NO BLOCKOUTS, USING RIB-BAK W-BEAM LINE POSTS

SHEET NO.	DATE
1 of 1	27/04/07

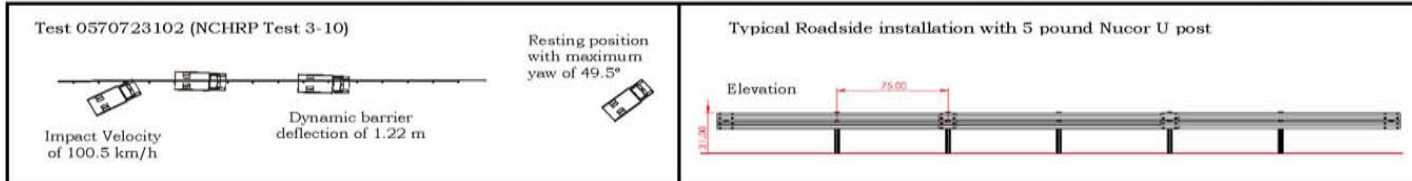

**General Information**

Test Agency ..... Holmes Solutions, New Zealand  
 Test Designation ..... NCHRP 350 Test 4-12  
 Test No. .... 0570734121  
 Date ..... 5 December 07

**Test Article**

Type ..... Nucor 31" strong post W-beam roadside guardrail system on 5 pound Nucor U posts  
 Name or Manufacturer... Nucor  
 Installation Length..... 55.4 m  
 Material or Key Elements AASHTO SGR04a-b Guardrail with 5 pound Nucor U posts  
 Soil Type and Condition.. AASHTO 'standard' soil M147-64

**Test Vehicle**

Type .....  
 Designation ..... 8000S  
 Model ..... Mitsubishi Fuso Fighter  
 Mass (kg) .....  
 Curb ..... 5030.0  
 Test Inertial..... 8050.0  
 Dummy ..... n/a  
 Gross Static ..... 8050.0

**Impact Conditions**

Speed (km/h) ..... 78.3  
 Angle (deg) ..... 15.0

**Exit Conditions**

Speed (km/h) ..... n/a  
 Angle (deg) ..... ≈5.0

**Occupant Risk Values**

Impact Velocity (m/s)  
 x-direction ..... 1.0  
 y-direction ..... -2.5  
 THIV (km/h) ..... 10.0  
 Ridedown Accelerations  
 x-direction (g's) ..... -2.9  
 y-direction (g's) ..... 3.4  
 PHD (g's) ..... 3.4  
 ASI ..... 0.22  
 Max. 0.050-s Average  
 x-direction (g's) ..... -0.9  
 y-direction (g's) ..... 2.0  
 z-direction (g's) ..... 1.2

**Test Article Deflections**

Dynamic (m) ..... 1.22  
 Permanent (m) ..... 0.80

**Vehicle Damage**

Exterior  
 VDS ..... 11LFQ-2  
 CDC ..... 11FLEN2  
 Maximum Exterior  
 Vehicle Crush (mm) ... 250  
 Interior  
 OCDI ..... AS0000000  
 Max. Occ. Compart.  
 Deformation (mm) ..... 1.0

**Post-Impact Behaviour**

Max. Yaw Angle (deg) ..... 49.2°  
 Max. Pitch Angle (deg) ... 4.7  
 Max Roll Angle (deg) ..... -16.9

\* Maximum yaw angle occurring after exiting barrier when remote brakes were applied

Figure 3.5 Summary of results for test 0570734121 (NCHRP 350 Test 4-12).