



ABSORB 350™ Crash Cushion Product Specifications

Product Specification: ABSORB 350™ TL-2

Non Re-directive, Gating, Crash Cushion Applied to Permanent or Portable Concrete Barrier

I. General

The ABSORB 350™ TL-2 System is a Non Re-directive, Gating, Crash Cushion in accordance with the definitions in the National Cooperative Highway Research Program Report 350 (NCHRP 350). The system shall be tested and perform in an acceptable manner in accordance with the guidelines of NCHRP 350 at Test Level-2 (70 km/h).

II. Performance

The ABSORB 350™ is designed to absorb the impact energy of an errant vehicle in accordance with NCHRP 350 guidelines for Non Re-directive, Gating, Crash Cushions. The system is designed to attach to Permanent or Portable Concrete Barrier (PCB) with section lengths of at least 3.1 metres. When attached in accordance with the manufacturers instructions, the ABSORB 350 system is capable of safely stopping a 2000 kg pickup truck impacting the system at 70 km/h and 0 degrees and an 820 kg compact vehicle impacting the system at 70 km/h, 0 degrees and with an offset of the vehicle and system centrelines of one-fourth the vehicle width.

A. When properly installed according to the manufacturer's recommendations the ABSORB 350™ system shall be fully tested to and meet the recommended structural adequacy, occupant risk, and vehicle trajectory criteria set forth in NCHRP 350 for Test Level 2 Non Re-directive, Gating, Crash Cushions (NCHRP 350 TL-2): Impact at 0 degrees at w/4 offset (centreline of vehicle offset 1/4 width of vehicle from centreline of system) at 70 km/h with an 820kg vehicle. This is Test 2-40 of NCHRP 350.

Installing the ABSORB 350™

The following is the installation and maintenance instructions for an Absorb 350™ System when it is attached to Portable or Permanent Concrete Barriers.

- Test level 2 and 3 configurations are the same with the exception of the number of Absorb 350™ elements used...
 - Test level 2 requires 5 Absorb 350™ elements
 - Test level 3 requires 9 Absorb 350™ elements

This system is designed to attach to Portable or Permanent Concrete Barrier with section lengths of at least 3.1 metres.

Terminology

The following pictures show the elements and assemblies that comprise the Absorb 350™ System.

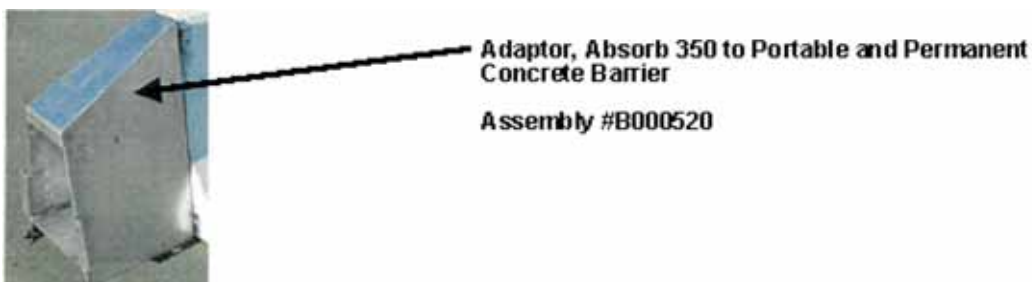
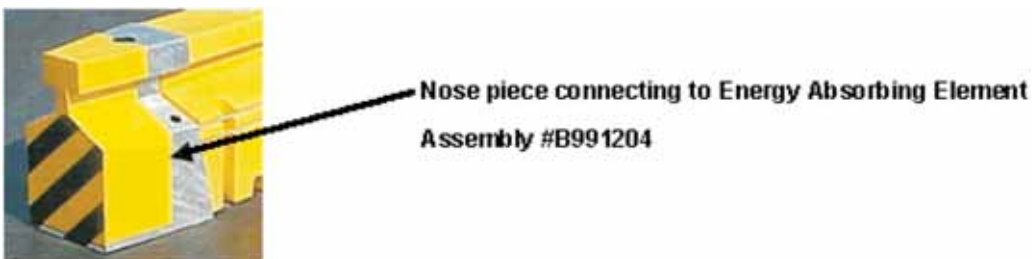
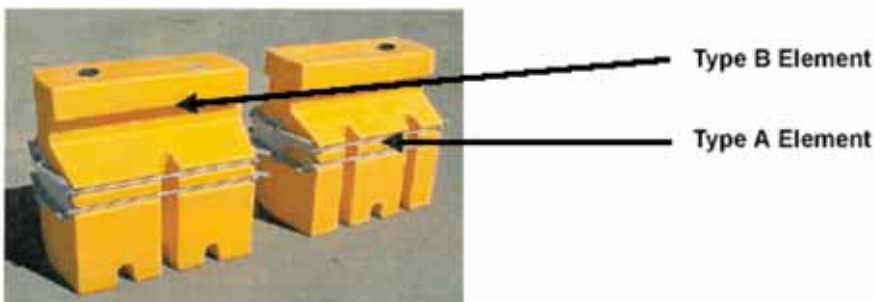

Installation Manual: ABSORB 350™ Crash Cushion

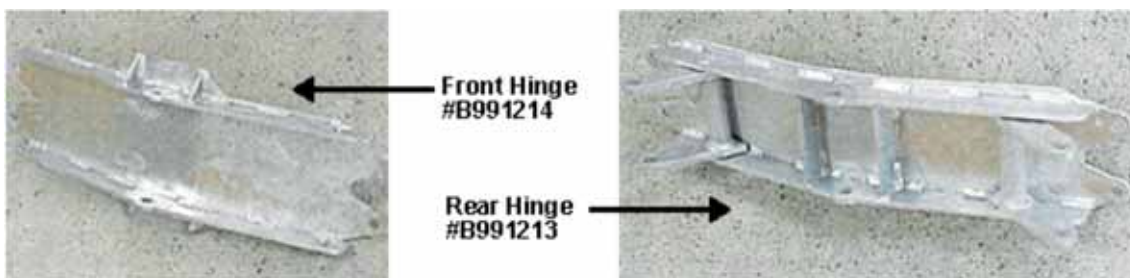

Link Hinge Pin #A991221



Figure 1: ABSORB 350™ TL2 & TL3 with PCB

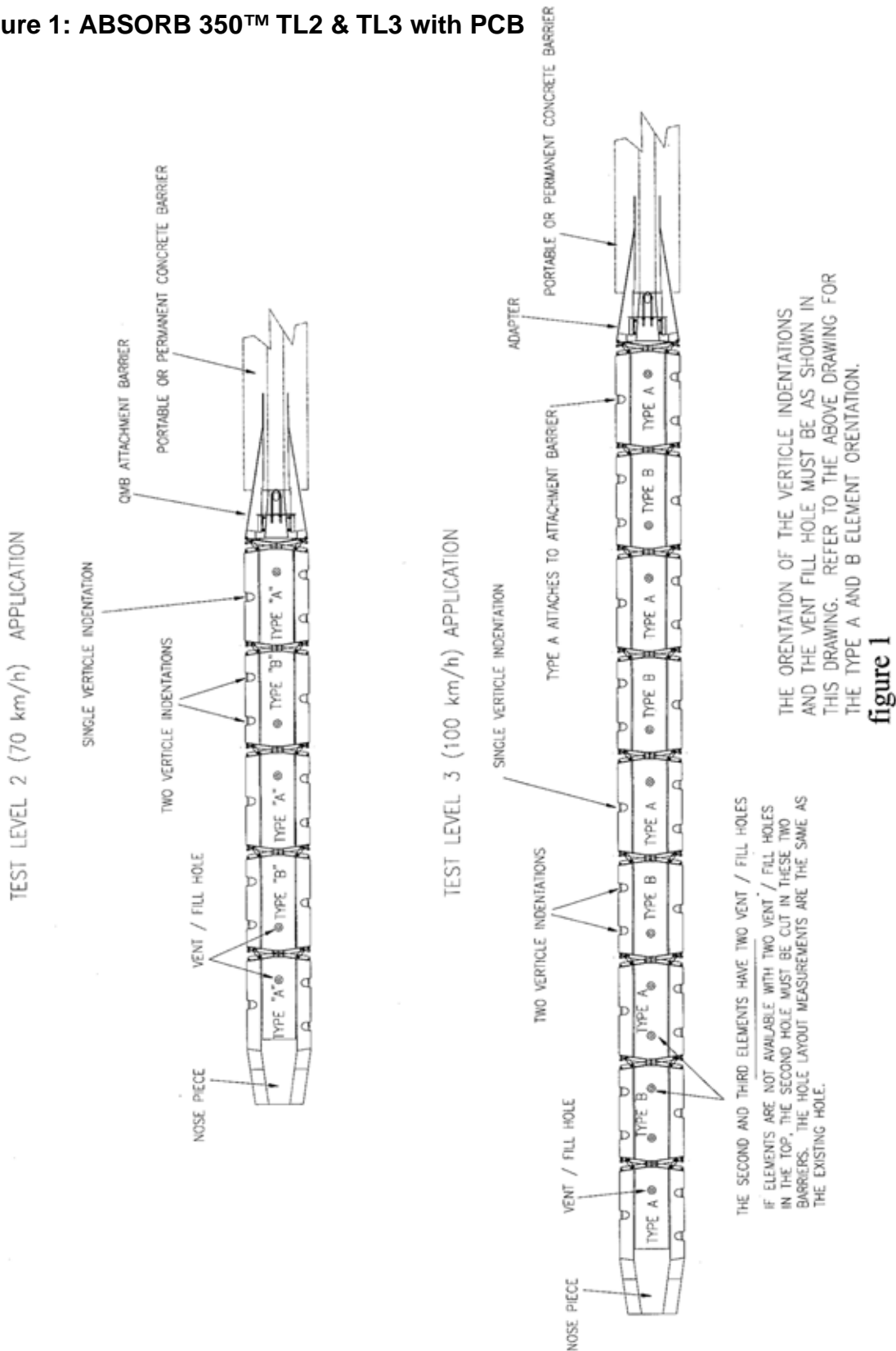

Installation Instructions

Two people can easily accomplish the initial installation. The installation should be completed prior to filling the energy absorbing elements with water. It is not necessary but is easier to start setting the assembly from the concrete barrier wall end and assemble towards the nosepiece.

STEP I

Install the Adapter to the Portable Concrete Barrier wall. Use the following steps to install the Adaptor.

Step 1.1



A000521

Place the two Anchor Bolts (A000521) into the Adapter (B000520) as shown. The bolts should be placed in the upper and lower holes if they will not interfere with the mounting on the end of the concrete barrier. If there is interference use the closest holes to the top and bottom that is possible.

B000520

Step 1.2

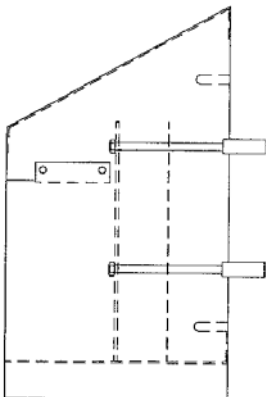

Place both anchor bolts through both plates as shown in the drawing. Start two nuts on each anchor bolt and push the anchor bolt to the rear until the nuts are against the plate.

Step 1.3

In the event that the taper adapter is installed on a permanent concrete wall, mounting bolts must be installed. The taper adapter should be set against the wall in its proper position. A punch can be used to mark the concrete in the four spots that the anchor bolts shown above would be located. Then four 12.5mm wedge anchor bolts need to be installed. Then install the taper adapter, torque the 12.5mm nuts on the wedge anchor bolts to 54.23 Nm.

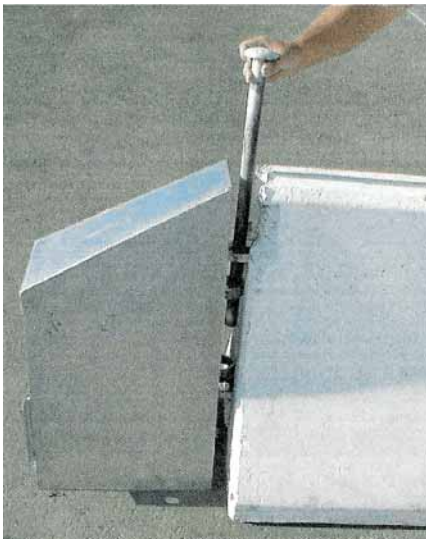

Place the adapter at the end of the Portable Concrete Barrier wall. Insert the Portable Concrete Barrier pin through the two loops of the Portable Concrete Barrier and the two loops of the anchor bolts as shown.

Tighten the four nuts on the Anchor Bolts to a torque of 15 ft/lbs. Then install a jam nut against the first nut with a torque of 54.23 Nm.

Step 1.4

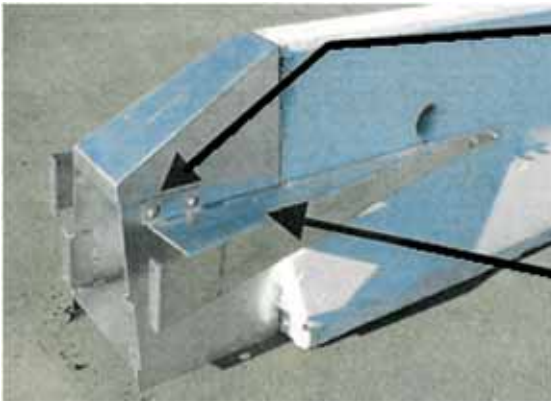

Bolt the left and right Strap Adapter to the Taper Adapter. BOO0207 & BOO0209

Hold the top edge of the Strap Adaptor parallel with the road surface. Mark the rear holes (2) of the Strap Adaptor on the concrete barrier.

Step 1.5

At each of the four (4) marks made above on the Portable Concrete Barrier drill a 12.5mm diameter hole 94mm deep.

Step 1.6



Install four (4) 12.5 x 106mm (wedge anchor) cement anchor bolts. Place one 12.5mm flat washer and nut on each anchor bolt. Torque the nuts to 54.23 Nm.

Step 1.7

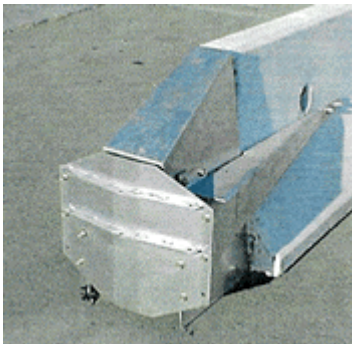

Install the Hinge Plate Adapter (B000611) onto the Taper Adapter as shown with eight (8) 12.5mm X 32mm NC GR 5 CADII PLTD bolts

STEP 2

Install the first Energy Absorbing Element (Type "A") to the Hinge Plate Adapter. For element assembly see pages C-10 and C-11.

Step 2.1

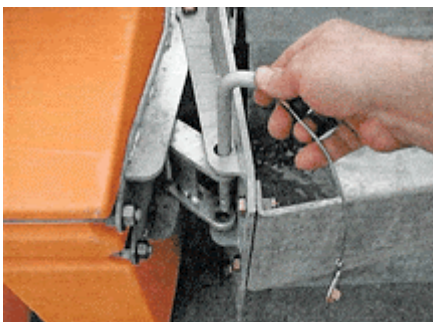

Install the centre pivot bolt, 12.5mm X 200mm and 12.5mm nylock nut. Tighten the nut only until the end of the bolt threads protrude out of the nylon portion of the nut.

Step 2.2



Install a Link Hinge Pin on each side of the hinge. Then make sure that the clip that is attached to the end of the chain is installed into the hole in the end of the Link Hinge Pin.

STEP 3

Install the Energy Absorbing Elements. Install the Centre Pivot Bolt and the two Link-Hinge Locking Pins on each element.

Test Level 2 - install five (5) elements total **Test Level 3** - install nine (9) elements total.



There are two types of Energy Absorbing Elements. Each type has a forward and rearward end. The forward end is considered the end that faces the Nose Piece. The rearward end faces the Concrete Barrier wall. The two types of elements are identified by the number of vertical indentations along each side in relation to the front and rear hinges. See elements on page C-1.

When the Absorb 350™ system is assembled, it is important to ensure that the two types of elements are ALWAYS ASSEMBLED IN AN ALTERNATING FASHION as shown in Figure 1. Thus, when you look down either side of the assembled system, you should see an alternating pattern of vertical indentations (i.e. two, one, two, one, etc.).

NOTE: The second and third elements of Test Level 3 systems must have two vent/fill holes. If elements are not available with the two vent/fill holes in the top, the second hole must be cut in these two elements. The whole layout and size measurements are the same as the existing hole. See figure 1 drawing of Test Level 3.

STEP 4

Six tabs are loosely bolted (so they swivel for adjustment) onto the last hinge assembly before the Nose Piece. These tabs are the mounting points for the nosepiece. Three of the tabs have nuts welded onto one end. These go on the top of the bottom bar of the hinge assembly. The three tabs with a hole in each end go on the bottom side of the top bar of the assembly as shown below. (These tabs may already be installed.)

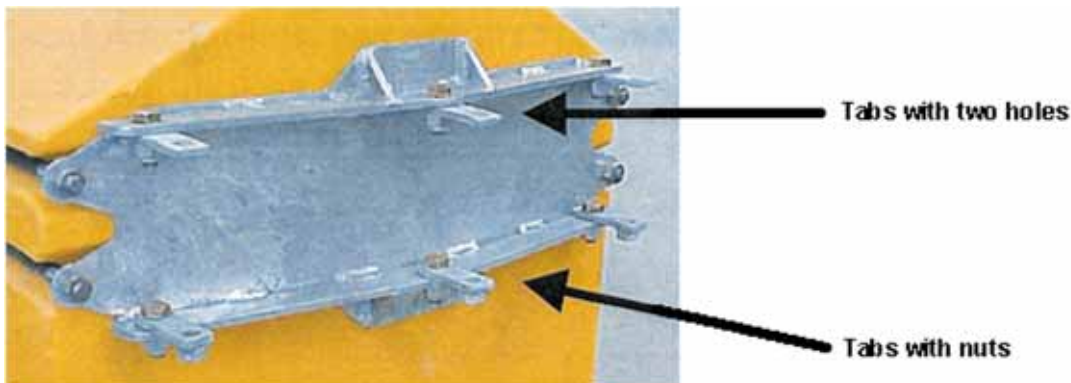

STEP 5

Install the nosepiece on the end of the last Type A element. There are three 12.5mm X 150mm bolts that secure the nosepiece to the tabs on the hinge assembly. There are three access holes in the nosepiece that allows installation of these bolts. These bolts must be securely tightened. It is very important that the Nose Piece does not become detached during an impact.

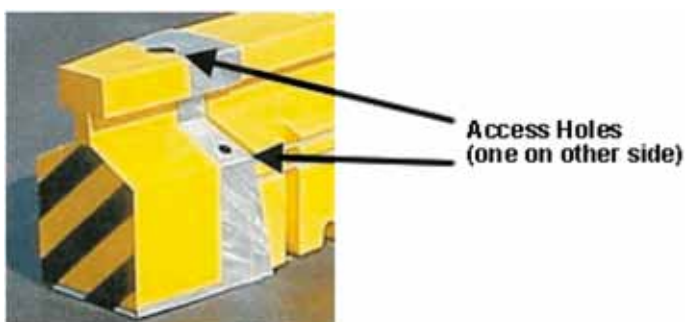

STEP 6

If necessary adjust the Energy Absorbing Elements so there is a straight alignment with the downstream QMB system.

STEP 7

Fill all of the Energy Absorbing Elements with water, except the first element. The plastic container that attaches to the nosepiece is the only container that does not have any water. The remaining containers are filled with water to a level that is within 50mm from the top of the container.

Test Level 2: Fill 4 elements **Test Level 3:** Fill 8 elements

NOTE: Filling the element attached to the nose piece with water will cause the system to perform improperly and may cause serious bodily injury.

In regions where the water filled Absorb 350™ elements could become frozen, proper antifreeze agents should be used. Care should be taken to ensure that proper antifreeze agents are used in accordance with local regulations, environmental concerns and ensuring that any post impact liquid on the road surface does not constitute an undue hazard to adjacent motorists.

The Absorb 350™ elements should be inspected regularly to ensure that the elements that are intended to contain water (or antifreeze fluid) are kept at adequate fill levels.

STEP 8

Install the evaporation prevention cap into the top of each plastic container.



The cap needs to be securely pushed down to prevent evaporation. In addition the tie strap should be securely fastened to the plastic element.

STEP 9

Installing delineation: Depending on local authority specifications, install delineation as necessary to the front of the painted nosepiece.

Inspection:

The metal components and fasteners of the system should be periodically inspected to ensure that the system remains intact and able to perform in a safe and effective manner.

Replacement of damaged units:

Any component within the system that becomes damaged should be replaced immediately.

Assembly of Energy Absorbing Elements

It is necessary to determine if a Type A Element or a Type B Element is to be assembled. A Type A can be converted to a Type B or vice versa simply by reversing the plastic within the hinge system. Follow the instructions outlined below.

Figure 2: ABSORB 350 Element Assembly

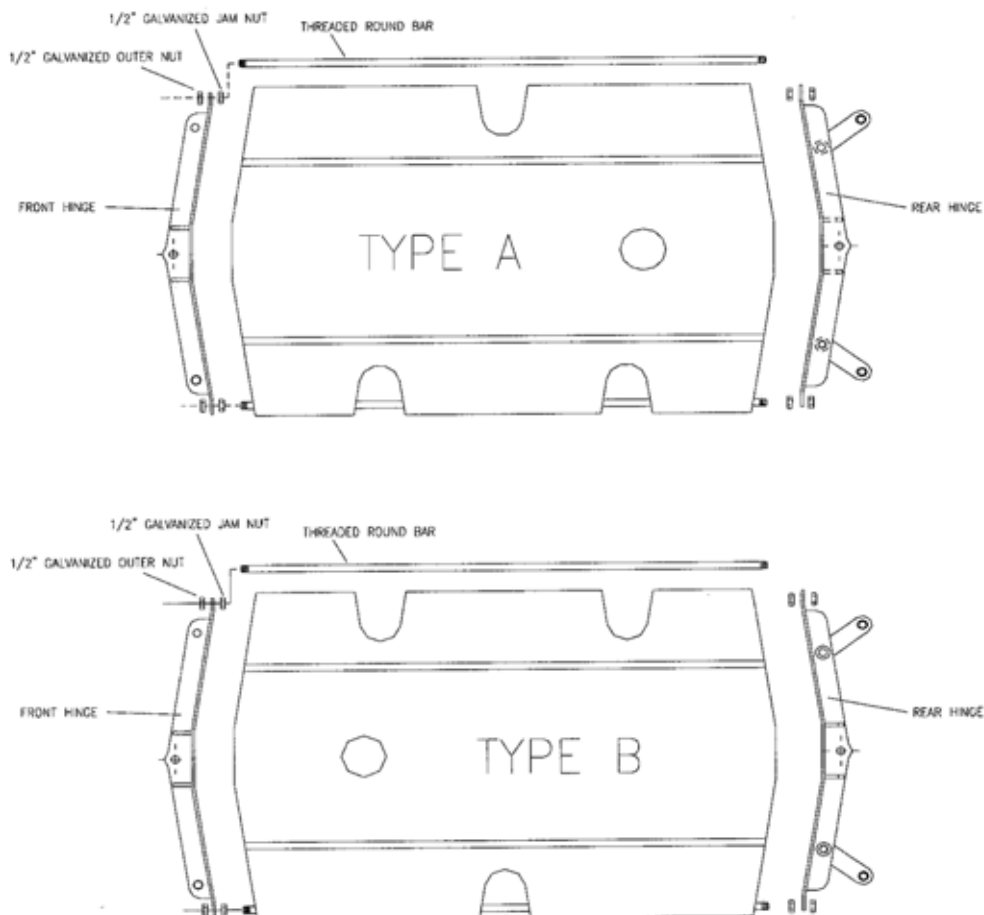

STEP 1

Install the 12.5mm galvanised jam nuts onto one end of the four threaded rods. The nut on each end should be threaded on the rod about 37mm.

STEP 2

Install the four threaded rods through the hinge ends and in the horizontal grooves of the energy absorbing element as shown above and loosely start the 12.5mm nuts. It is sometimes easier to secure all four rods to one hinge end, then slide this assembly onto the element, then attach the opposite hinge end.

STEP 3

Evenly tighten the outer 12.5 mm until the hinge assembly on each end is making firm contact with the energy absorbing element. After this adjustment is made, tighten each of the four outer nuts one full turn.

STEP 4

Thread the jam nuts against the backside of the hinges. Torque the jam nuts to 54.23Nm

NOTE: Please ensure you have read and understood the Limitations and Warnings Information provided in the front of this product manual before beginning any installation procedures.