

CSP Pacific's focus is on the supply of safety products and solutions for the roading industry. Our products include crash barriers and terminals, traffic control message boards and RRPMS, street lighting and flood lighting poles and large engineered drainage and road separation structures.



MassBloc™ Permeable Segmental Retaining Wall Solution



MASSBLOC™

A Simple, Straightforward Retaining Solution

MassBloc™ (patent approved) is a large permeable concrete block manufactured under stringent quality controls. Construction is mortarless and blocks can be placed using either an excavator or a tractor bucket. The rough exposed concrete surfaces of the block aid the resistance to shearing by increasing the friction between units.

MassBlocs™ are competitively priced and, when all project costs are measured and compared against the speed of installation, durability and in-situ performance, they represent excellent value for the construction dollars invested.

Easy to install, totally permeable, suitable for temporary or permanent situations.

For more information contact CSP Pacific on
Ph 0800 655 200 or visit www.csppacific.co.nz

Product info

Oct 04



MassBloc™ Permeable Segmental Retaining Wall Solution

Isometric Drawing

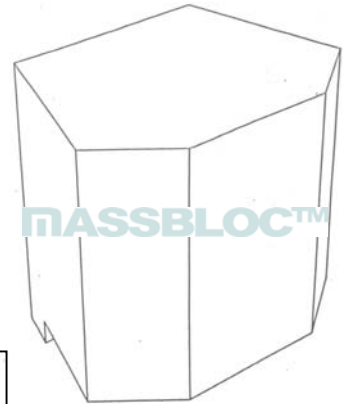
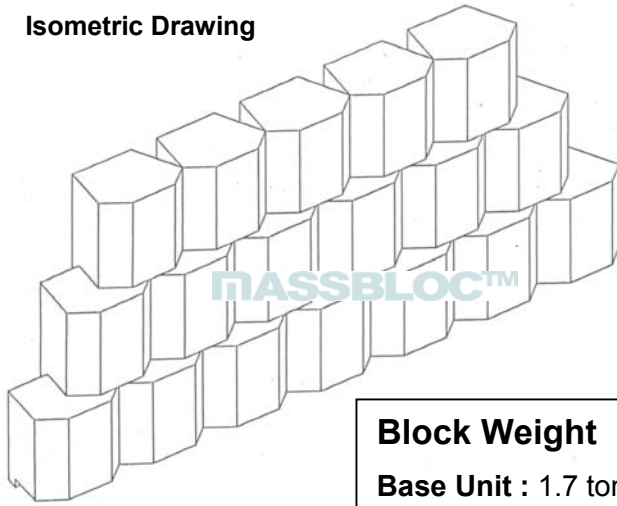

Block Weight
Base Unit : 1.7 tonne
Standard Unit : 1.8 tonne

Base Plan View

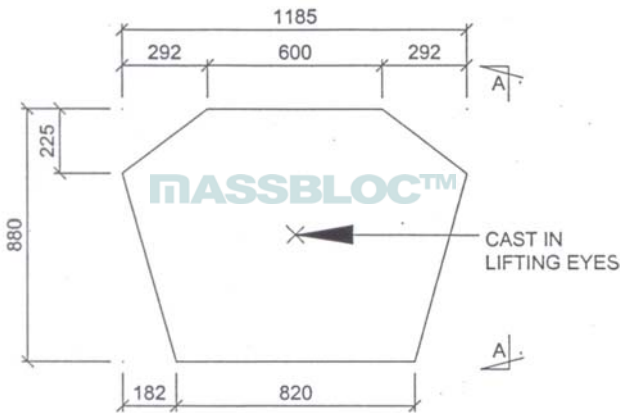

Base Unit (Section A-A)

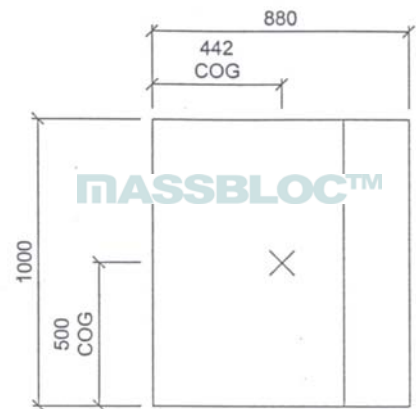

Standard Plan View

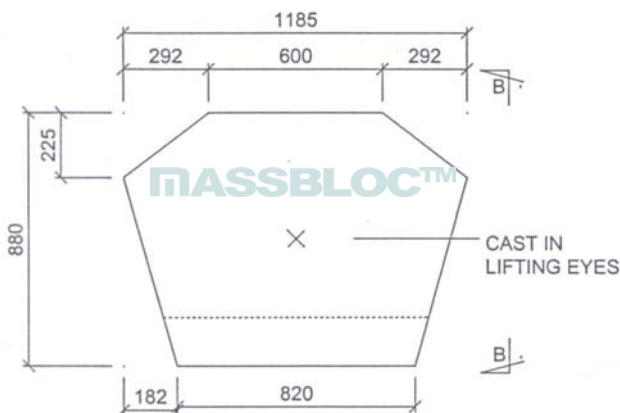

Standard Unit (Section B-B)

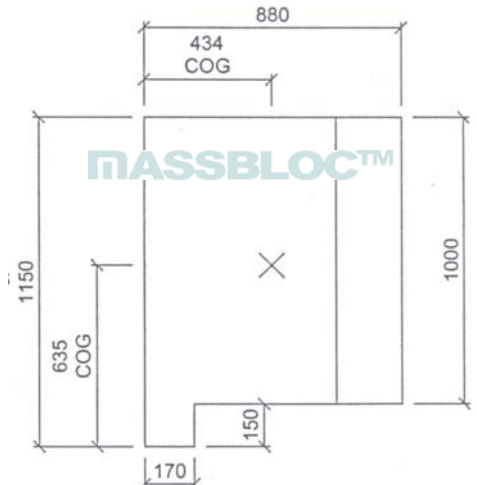

For more information contact CSP Pacific on
Ph 0800 655 200 or visit www.csppacific.co.nz