



Flexrail™ W-Beam Highway (12g) & Bridge Barrier (10g)



Flexrail™ complies with the requirements of AASHTO, AS/NZS 3845 : 1999 TNZ specifications M/23 and M/17P.

CSP Pacific supplies two standard types of **Flexrail™** W-beam guardrail:

- » Highway Flexrail: 3810-12
- » Bridge Flexrail: 4000-10

Flexrail™ is roll formed from coil steel and sheared to length. It is then punched, slotted and hot dip galvanised in accordance with the appropriate standards.

Flexrail™ is generally available ex-stock in standard net lengths of 3.81 metres and 1.905 metres for highway rail and 4.00 metres and 2.00 metres for bridge rail.



Physical Properties

	Highway (12g)	Bridge (10g)
Effective Cover	3810	4000
Steel Thickness (mm)	2.7	3.4
Area of Cross Section (mm ²)	1350	1640
Section Modulus (mm ³)	Major 80,000	Major 103,000
	Minor 22,000	Minor 29,000
Mass (kg per metre)	11.3	13.4

Profile

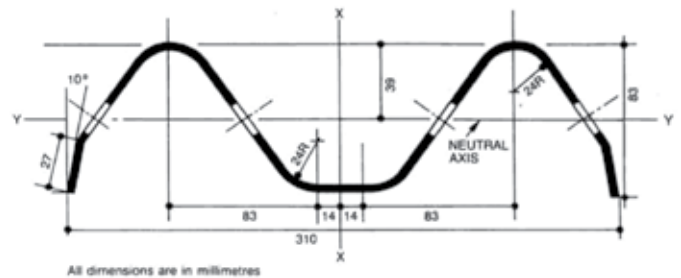

More information on **Flexrail™** can be found at www.csppacific.co.nz or call **0800 655 200**

Leading road side and barrier systems supplier

CSP PACIFIC

306 Neilson St, Onehunga,
PO Box 12 949, Penrose,
Auckland 1642, New Zealand
www.csppacific.co.nz



Columns ■



Multiplate ■



Retaining ■



Hire ■



Barriers ■



Traffic Control ■



Flexrail™ W-Beam Highway (12g) & Bridge Barrier (10g)

Backing Piece

(used on steel blockouts only)

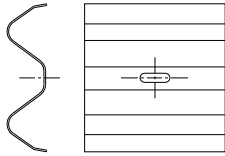

Fish Tail

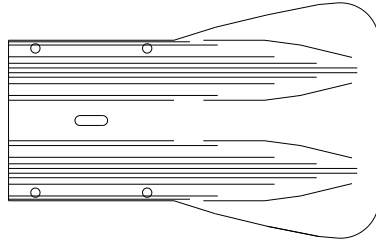

Rolled End Fitting

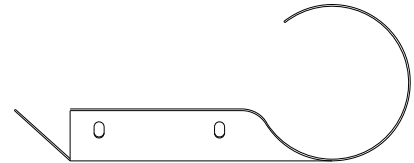

Bullnose End Fitting

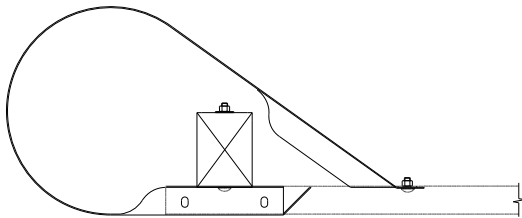

Structure Connector

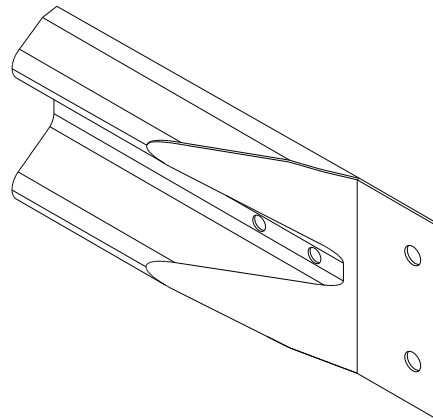

Post Bolt

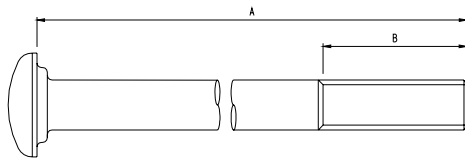

Bolt Size	A mm	B mm
250	25	120
350	350	80
450	450	120

Steel Post

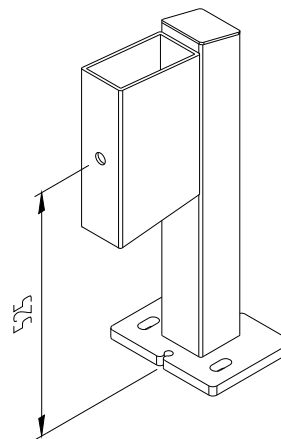

Wooden Post

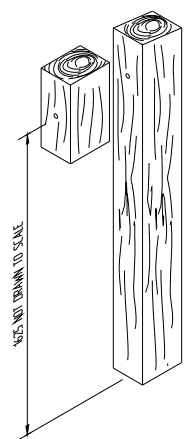

Splice Bolt

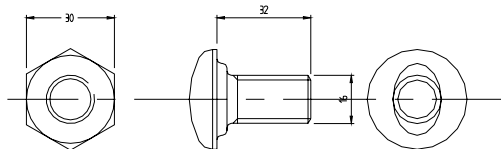

More information on Flexrail™ can be found at www.csppacific.co.nz or call **0800 655 200**

Leading road side and barrier systems supplier

CSP PACIFIC

306 Neilson St, Onehunga,
PO Box 12 949, Penrose,
Auckland 1642, New Zealand
www.csppacific.co.nz



Columns



Multiplate



Retaining



Hire



Barriers



Traffic Control



Flexrail™ W-Beam Highway (12g) & Bridge Barrier (10g)

Highway Rail (2.7mm Gauge)

Bridge Rail Dimensions (3.4mm Gauge)

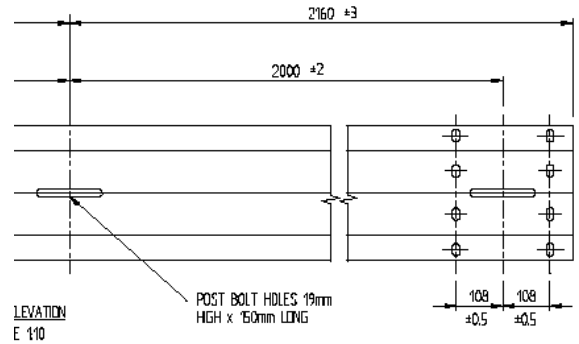
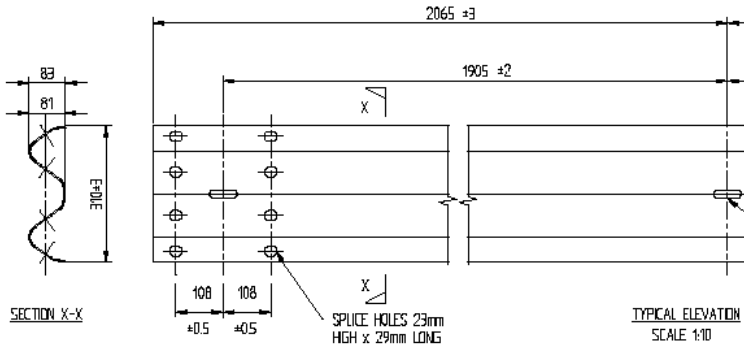

Curved Flexrail™

The standard straight section will align to give a smooth transition on curves with a radius greater than 45m. Pre-curved **Flexrail™** is required for tighter radii and may be curved to traffic face concave or convex. NB: Only Highway Flexrail is available pre-curved.

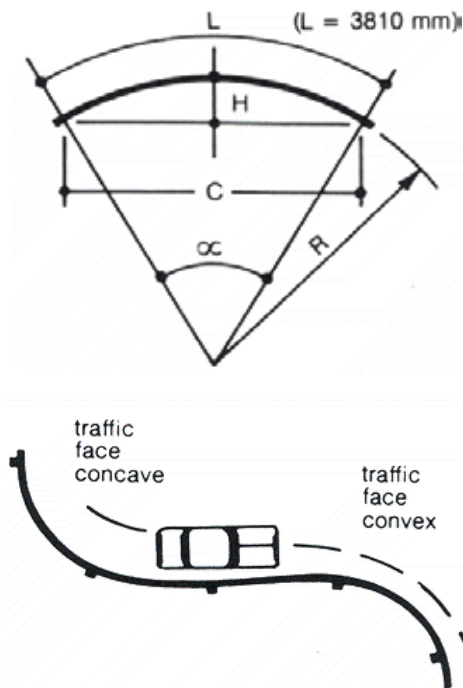

Highway Rail			
R (metres)	α (Deg)	C (m)	H (mm)
3	72.7656	3.559	585
4	54.5742	3.667	445
5	43.6594	3.719	359
6	36.3828	3.746	300
7	31.1853	3.763	258
8	27.2871	3.774	226
9	24.2552	3.782	201
10	21.8297	3.787	181
12	18.1914	3.794	151
14	15.5926	3.798	129
16	13.6436	3.801	113
20	10.9148	3.804	91
23	9.4912	3.806	79
29	7.5275	3.807	63
32	6.8218	3.808	57
35	6.2371	3.806	52
41	5.3243	3.809	44
46	4.7456	3.809	39

More information on **Flexrail™** can be found at www.csppacific.co.nz or call **0800 655 200**

Leading road side and barrier systems supplier

CSP PACIFIC

306 Neilson St, Onehunga,
PO Box 12 949, Penrose,
Auckland 1642, New Zealand
www.csppacific.co.nz



Columns



Multiplate



Retaining



Hire



Barriers



Traffic Control



Flexrail™ W-Beam Highway (12g) & Bridge Barrier (10g)

Installation Checklist

Checklist	Y	N
Assembly and installation is to be generally in accordance with TNZ M23, AS/NZS 3845:1999 and CSP Pacific drawing FX360 and/or the Engineers specification.		
The rail height (top) is in accordance with the plans (706mm above the edge of the shoulder or the ground line).		
Correct lapping of the rail should be away from the direction of traffic to prevent snagging.		
Timber blockouts should be nailed to timber post to prevent rotation.		
Installation is aligned and level.		
Posts are aligned at correct spacing and backfill compacted.		
Post bolts are tight and a 50 x 50 square washer is fitted to back of post.		
Steel Post Systems (Post Type FX91, FX92, FX93 & FX94)		
Backing pieces to be fitted at the intermediate post only.		
Post bolts are tight using a spring washer and then locked with a lock nut.		
Necked bolts are installed with washer as specified and are installed tight.		

Notes:

Location:			
Installed by:		Date:	
Inspected by:		Date:	

More information on **Flexrail™** can be found at www.csppacific.co.nz or call **0800 655 200**

Leading road side and barrier systems supplier

CSP PACIFIC

306 Neilson St, Onehunga,
PO Box 12 949, Penrose,
Auckland 1642, New Zealand
www.csppacific.co.nz



Columns ■



Multiplate ■



Retaining ■



Hire ■



Barriers ■



Traffic Control ■